

# EP-M650H

Eight Laser Large-size  
Metal Additive Manufacturing System

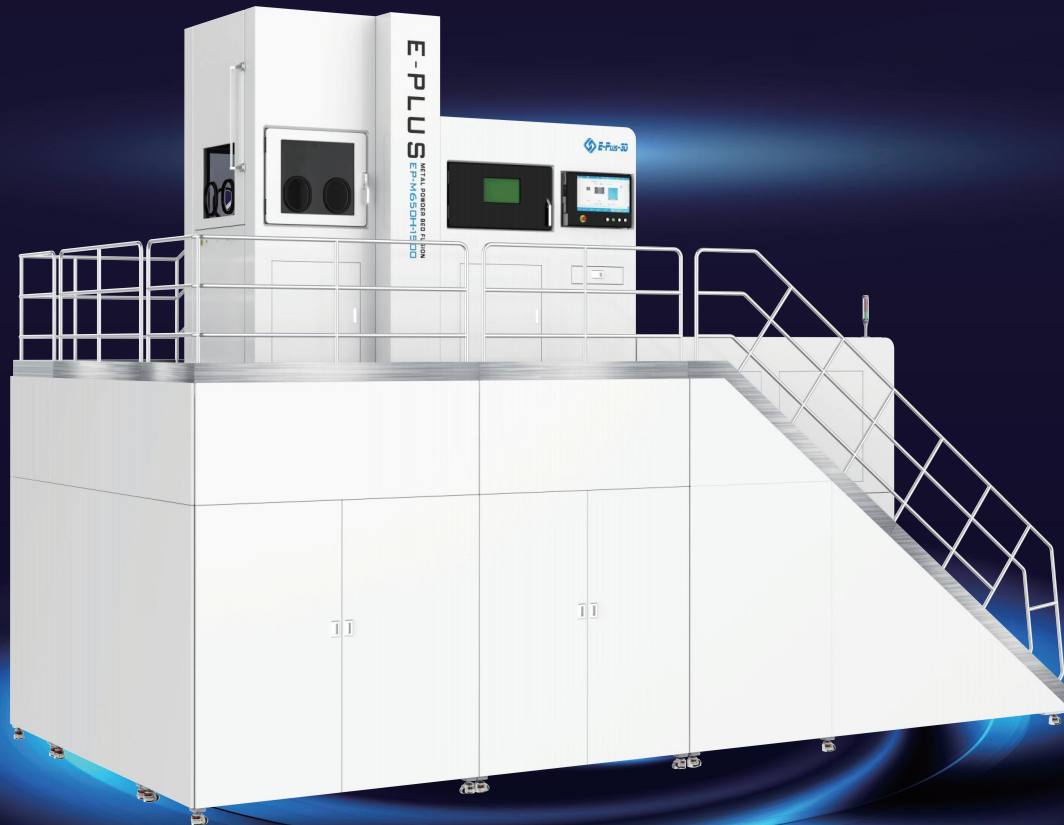

# EP-M650H

EP-M650H adopts MPBF™ metal powder bed fusion technology together with large size of the forming chamber, equipped with 4/6/8 lasers and four vibration mirrors, multi-laser precise positioning and splicing area precision control technology, to ensure high-quality, high-efficiency and high-stability printing of the equipment.

Printable powder material include titanium alloy, aluminum alloy, nickel alloy, maraging steel, cobalt chrome, etc. It's suitable for direct manufacturing of large-scale, high-precision and high-performance parts.

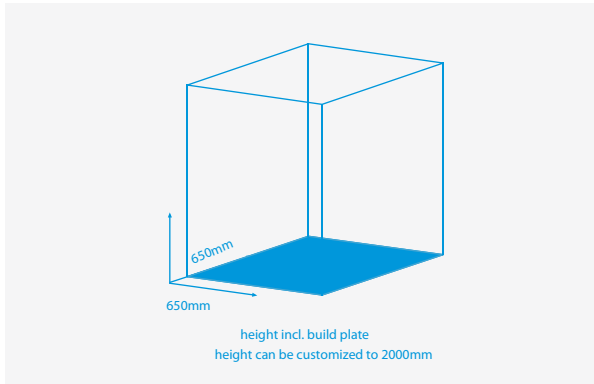

## ◀ STABLE QUALITY & GOOD CONSISTENCY

- Excellent and stable high beam quality.
- Optimized design of gas flow ensures the effective removal of dust and splatter.
- The strict calibration ensures the consistency between parts and batches.
- Tightly sealed build chamber maintains oxygen concentration  $\leq 100$  ppm and a stable pressure during printing.

## ◀ HIGH EFFICIENCY & PRODUCTIVITY

- Printing of mass-individualized parts in 460 to 845 Liter build chamber.
- Four lasers are printing simultaneously with speed up to  $320 \text{ cm}^3/\text{h}$ .
- Bi-directional powder recoating method leads to reduced recoating time.



## » HUMANIZED DESIGN & HIGH AUTOMATION

- Fully automatic user-friendly one click printing button frees your hands.
- The build job information is displayed in real time with traceable printing parameters report.
- The one-piece take out function ensures a high automation.



## « REAL TIME MONITORING & HIGH SECURITY

- Safety design, prevent mis-operation, electric shock, fire, waste and pollution.
- Outstanding overall sealing performance, use and recovery of powder in a closed state.
- Environment and gas source state real time monitoring, safe and reliable.

## » PERFECT AFTER-SALE SERVICE

- We support our customers with technical consulting services, including data evaluation, application development.
- Assisting our customers in new material parameter development, existing parameter packages are provided free of charge.
- Free equipment installation and maintenance during warranty period, full set of technical training is provided.



Safe Design



Electricity-proof



Misoperating



Fire-proof



Anti-pollution



Environment  
Real Time  
Monitoring



Gas Real Time  
Monitoring



Waste  
Prevention

# EP-M650H

## PARAMETER

Machine Model	EP-M650H
Build Volume (X x Y x Z) (height incl. build plate)	650 x 650 x 1300 mm ( 25.59 x 25.59 x 51.18 in) (height can be customized to 2000 mm / 87.74 in)
Optical System	Fiber Laser 4 / 6 / 8 x 500 W (700 W and 1000 W are optional)
Spot Size	70 - 120 $\mu$ m
Max Scan Speed	8 m/s
Layer Thickness	20 - 120 $\mu$ m
Theoretical Printspeed	Up to 280 cm <sup>3</sup> /h
Material	Titanium Alloy, Aluminum Alloy, Nickel Alloy, Maraging Steel, Stainless Steel, Cobalt Chrome, Copper Alloy, etc.
Substrate Heating	Substrate Heating Temperature 200 °C
Power Supply	380 V, 50 / 60 Hz, 20 ~ 32 kW
Gas Supply	Ar / N <sub>2</sub>
Oxygen Content	≤100 ppm
Dimension (W x D x H)	7730 x 4330 x 5500 mm
Weight	25000 kg
Software	EPControl, EP Hatch
Input Data Format	STL or other Convertible File

Notice: Eplus3D reserves the right to explain any alteration of the specifications and pictures.