

EP-M3050

Three-Meter-Class Ultra-Large Format
Metal PBF System

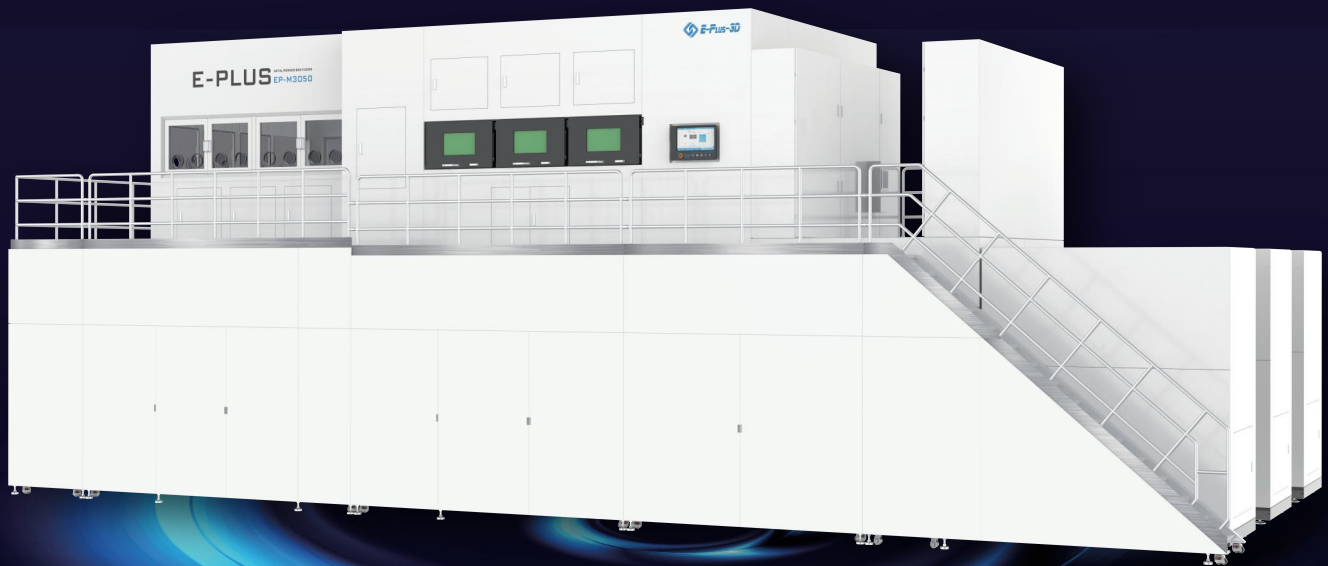

EP-M3050

EP-M3050 adopts Metal Powder Bed Fusion (MPBF™) technology, featuring an ultra-large build chamber exceeding 3050 x 3050 x 1200 mm, with a configurable Z-axis up to 5000 mm. Equipped with a high-density multi-laser system (up to 256 lasers), the EP-M3050 incorporates advanced technologies in multi-laser coordination, large-scale airflow control, and process stability across meter-scale build areas.

Compatible with titanium alloy, aluminum alloy, nickel alloy, maraging steel, stainless steel, cobalt chrome, copper alloy, etc., EP-M3050 is designed to enable the integrated manufacturing of ultra-large, high-performance components for aerospace & aviation, energy, oil & gas, machinery, and other demanding industrial applications.

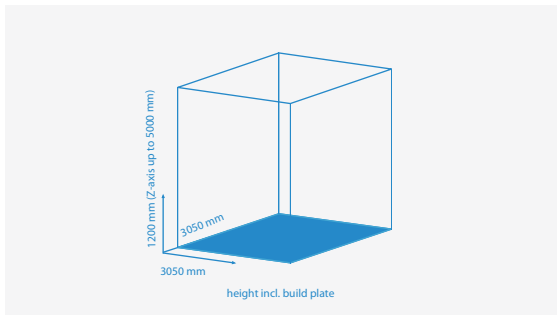

« BREAKTHROUGH IN LARGE-FORMAT MANUFACTURING

- Build volume exceeding 3050 x 3050 x 1200 mm, with configurable Z-axis up to 5000 mm.
- Supports one-piece forming of ultra-large structures.
- Reduces assembly complexity and improves structural integrity.

» STABLE PROCESS CONTROL AT EXTREME SCALE

- Advanced airflow management for uniform process conditions.
- Efficient removal of smoke and by-products across large build areas.
- Maintains optical system stability and cleanliness during extended builds.

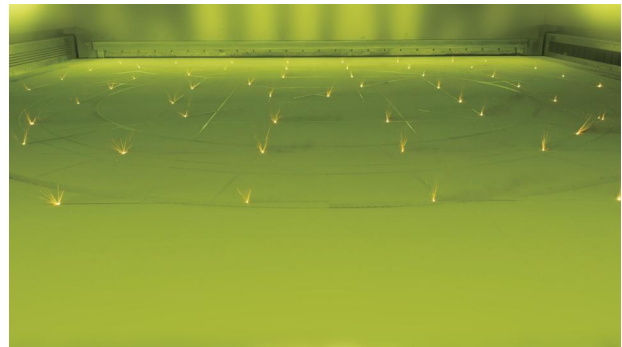



« HIGH-PRODUCTIVITY MULTI-LASER SYSTEM

- Equipped with 100 lasers, expandable up to 256 lasers.
- Build rate up to 3500 cm³/h.
- Optimized scan strategies ensure uniform coverage and consistency.

» FLEXIBLE BUILD CONFIGURATIONS

- Square and cylindrical build chambers available.
- Optional ring-shaped configuration for special structures.
- Improves adaptability for complex and large components.



Safe Design



Electricity-proof



Misoperating



Fire-proof



Anti-pollution



Environment
Real Time
Monitoring



Gas Real Time
Monitoring



Waste
Prevention

« ENABLING NEXT-GENERATION MANUFACTURING

- Supports transition to large-scale, integrated manufacturing.
- Extends metal AM from prototyping to industrial production.
- Provides a scalable solution for future manufacturing demands.

EP-M3050

PARAMETER

Machine Model	EP-M3050
Build Volume (X x Y x Z) (height incl. build plate)	3050 x 3050 x 1200 mm (Z-axis up to 5000mm) (120.08 x 120.08 x 47.24 in)
Optical System	Fiber Laser 100 / 256 x 500 W (700 W and 1000 W are optional)
Spot Size	70 - 120 μ m
Max Scan Speed	8 m/s
Layer Thickness	20 - 120 μ m
Theoretical Printspeed	Up to 3500 cm ³ /h
Material	Titanium Alloy, Aluminum Alloy, Nickel Alloy, Maraging Steel, Stainless Steel, Cobalt Chrome, Copper Alloy, etc
Power Supply	380 V, 50 / 60 Hz, 135 kW
Gas Supply	Ar / N ₂
Oxygen Content	≤100 ppm
Dimension (W x D x H)	17420 x 8425 x 6740 mm
Weight	220000 kg
Software	EPControl, EPHatch
Input Data Format	STL or other Convertible File

Notice: Eplus3D reserves the right to explain any alteration of the specifications and pictures.